



### The most durable 3-moving part tool from HYTORC!

When bolting speed is imperative, simplicity in use, light weight, small size and built-in durability become a must.

Hytorc's field-proven mechanism has been perfected over the years. The best alloys available combined with safety-oriented engineering and precision machining, make the EDGE-Wrench the one others are compared to for safety, simplicity, accuracy and quality. With 75% fewer parts, sturdy Uni-body Design and Anti-Lock Pawl System, Hytorc's EDGE is the best.

#### EDGE™ Features

- 360 degree Uni-swivel and 60 point
- Exclusive Precision-tooth Ratchet for accuracy
- One-piece, bind-free push-through drive
- Exclusive Radius, Throat and Head Contour for fit
- Long Stroke Design with Anti-lock feature
- Hands-free operation for safety
- Just 3 moving parts
- Anti-lock ratchet
- Uni-body housing
- Dual Axis Swivel
- More turns per stroke
- Use of the highest tensile strength Alloy
- 360° adjustable reaction arm
- Nothing compares in Quality and Price

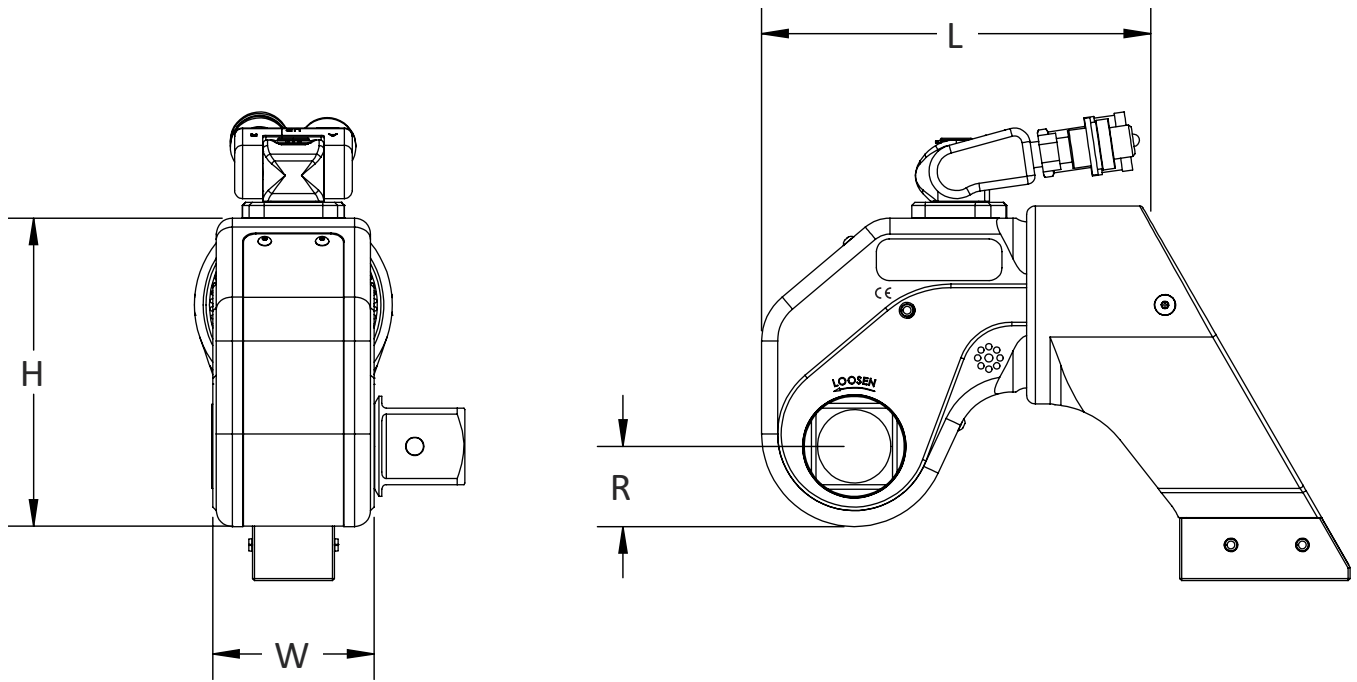

LEGEND: H = HEIGHT W = WIDTH L = LENGTH R = RADIUS

MODEL NUMBER	H	W	L	R	SQUARE DRIVE	WEIGHT	TORQUE	
IMPERIAL				in.		lbs.	ft-lbs (Min)	ft-lbs (Max)
EDGE-1S	3.53	1.97	4.94	0.97	3/4	4.05	178	1,257
EDGE-3S	4.71	2.63	6.40	1.31	1	8.50	443	3,097
EDGE-6S	6.04	3.18	7.61	1.57	1-1/2	19.20	893	6,241
EDGE-9S	6.58	3.57	8.59	1.86	1-1/2	20.05	1,230	8,555
EDGE-11S	7.07	3.95	9.60	1.96	1-1/2	25.00	1,615	11,291
EDGE-30S	10.10	5.64	13.71	2.79	2-1/2	64.70	4,448	29,650
METRIC				mm		kg	Nm (Min)	Nm (Max)
EDGE-1S	90	50	125	25	3/4	1.84	241	1703
EDGE-3S	120	67	163	33	1	3.86	600	4172
EDGE-6S	153	81	193	40	1-1/2	8.73	1210	8457
EDGE-9S	167	91	221	47	1-1/2	9.11	1667	11592
EDGE-11S	180	100	244	50	1-1/2	11.36	2188	15299
EDGE-30S	257	143	348	71	2-1/2	29.41	6027	40194

For further information, please contact:

**Dag Nedrum**  
Managing Director

+47 51 30 00 10

+47 906 84 522

dag.nedrum@petroproducts.com